

# Student Inquiry Handbook Index

|  |              |
|--|--------------|
| <b>General Overview . . . . .</b>                    | <b>2</b>     |
| <b>Youth Camp Stations. . . . .</b>                  | <b>3</b>     |
| <b>Sample Schedule . . . . .</b>                     | <b>4</b>     |
| <b>Elementary Student Sign-Up Sheet . . . . .</b>    | <b>5</b>     |
| <b>Middle School Student Sign-Up Sheet . . . . .</b> | <b>6</b>     |
| <b>High School Student Sign-Up Sheet. . . . .</b>    | <b>7</b>     |
| <b>Passport Overview . . . . .</b>                   | <b>8</b>     |
| <b>Passports . . . . .</b>                           | <b>9</b>     |
| <b>Station Instructions:</b>                         |              |
| <b>Level I-II</b>                                    |              |
| <b>Build a Thermometer. . . . .</b>                  | <b>10-13</b> |
| <b>Build an Anemometer . . . . .</b>                 | <b>14-17</b> |
| <b>Build a Weather Vane . . . . .</b>                | <b>18-21</b> |
| <b>Level III-IV</b>                                  |              |
| <b>Clouds As Art . . . . .</b>                       | <b>22-25</b> |
| <b>Water Cycle . . . . .</b>                         | <b>26-30</b> |
| <b>Build a Psychrometer. . . . .</b>                 | <b>31-34</b> |
| <b>Level V-VI</b>                                    |              |
| <b>Science Observation Network . . . . .</b>         | <b>35-36</b> |
| <b>Introduction to STELLA. . . . .</b>               | <b>37-39</b> |
| <b>The View from Space (GINA) . . . . .</b>          | <b>40-42</b> |

# Arctic Climate Modeling Program Youth Camp

## Overview

This handbook provides helpful guidelines for teachers and students setting up and leading the Arctic Climate Modeling Program (ACMP) Youth Camp stations. The Youth Camp consists of nine interactive stations demonstrating what students are learning through ACMP. Youth Camp attendees rotate through these stations, which are repeated throughout the day. Teachers and aides guide the stations with student assistance. When students are not assisting at a station, they rotate among the other stations. Sign up sheets are provided to encourage students to help lead a variety of stations. Please invite community members of all ages to attend the Youth Camp to learn more about student work with ACMP.

## Supplies

Each school will receive all the materials necessary for the Youth Camp in well-marked bins in the mail. These supplies are separate from the supplies needed for the ACMP classroom lessons. Enough supplies will be provided for each of the nine stations to be repeated at least six times.

## Stations

The stations are broken down by level. Elementary teachers, aides and students lead the elementary stations. Middle school teachers, aides and students lead the middle schools stations and high school teachers, aides and students lead the high school level stations. However, students and community members are encouraged to visit all stations. Therefore, presentations at each station should be geared toward all ages. Each station will be repeated at least six times during Youth Camp, depending on individual school preferences and schedules. Students of all ages are invited to attend all the stations. After each demonstration, ask visitors to the stations (both students and community members) to complete worksheets. Collect these worksheets in the envelopes provided and return them to the Geophysical Institute.

### Level I-II

Build a Thermometer  
Build an Anemometer  
Build a Weather Vane

### Level III-IV

Clouds as Art  
Water Cycle  
Build a Psychrometer

### Level V-VI

Science Observation Network  
Introduction to STELLA Computer Modeling  
The View from Space (GINA)

# Youth Camp Stations

Students and community members of all ages are invited to attend all stations. Therefore, presentations at each of the nine stations should be geared toward all ages. Activities at each station should last approximately 30 minutes. Students and community members will rotate through the stations. During an average school day at least six rotations should be possible.

## Level I-II

To be directed by elementary teachers with student assistance:



## Level III-IV

To be directed by middle school teachers with student assistance:



## Level V-VI

To be directed by high school teachers with student assistance:



## **Sample Youth Camp Schedule Arctic Climate Modeling Program**

|                  |                             |
|------------------|-----------------------------|
| 9:00-9:30 a.m.   | <b>Station 1</b>            |
| 9:30-9:45 a.m.   | <b>Walk to next station</b> |
| 9:45-10:15 a.m.  | <b>Station 2</b>            |
| 10:15-10:30 a.m. | <b>Walk to next station</b> |
| 10:30-11:00 a.m. | <b>Station 3</b>            |
| 11:00-11:15 a.m. | <b>Walk to next station</b> |
| 11:15-11:45 a.m. | <b>Station 4</b>            |
| 11:45-1:00 p.m.  | <b>Lunch</b>                |
| 1:00-1:30 p.m.   | <b>Station 5</b>            |
| 1:30-1:45 p.m.   | <b>Walk to next station</b> |
| 1:45-2:15 p.m.   | <b>Station 6</b>            |

Note: This sample schedule is intended to help organize the Youth Camp. It can be modified to reflect each school's schedule and preferences. The Youth Camp consists of nine 30-minute stations. Students will break into groups and rotate through the stations over the course of one school day. At least one teacher or aide leads each station, serving as a station leader as the different groups cycle through. Other teachers should be group leaders and timekeepers as needed. The Youth Camp should have a fun carnival-like atmosphere with community members of all ages invited to attend.

## ACMP Youth Camp Elementary Student Assistant Sign-Up

**Note:** Use this form to designate student assistants at the Youth Camp stations. Since the rotations for all stations occur at the same time, be sure that students do not sign up for the same rotation number more than once.

| Station                            | Name |
|------------------------------------|------|
| <b><i>BUILD A THERMOMETER</i></b>  |      |
| <i>Rotation 1</i>                  |      |
| <i>Rotation 2</i>                  |      |
| <i>Rotation 3</i>                  |      |
| <i>Rotation 4</i>                  |      |
| <i>Rotation 5</i>                  |      |
| <i>Rotation 6</i>                  |      |
|                                    |      |
| <b><i>BUILD AN ANEMOMETER</i></b>  |      |
| <i>Rotation 1</i>                  |      |
| <i>Rotation 2</i>                  |      |
| <i>Rotation 3</i>                  |      |
| <i>Rotation 4</i>                  |      |
| <i>Rotation 5</i>                  |      |
| <i>Rotation 6</i>                  |      |
|                                    |      |
| <b><i>BUILD A WEATHER VANE</i></b> |      |
| <i>Rotation 1</i>                  |      |
| <i>Rotation 2</i>                  |      |
| <i>Rotation 3</i>                  |      |
| <i>Rotation 4</i>                  |      |
| <i>Rotation 5</i>                  |      |
| <i>Rotation 6</i>                  |      |

## ACMP Youth Camp Middle School Student Assistant Sign-Up

**Note:** Use this form to designate student assistants at the Youth Camp stations. Since the rotations for all stations occur at the same time, be sure that students do not sign up for the same rotation number more than once.

| Station                     | Name |
|-----------------------------|------|
| <i>CLOUDS AS ART</i>        |      |
| <i>Rotation 1</i>           |      |
| <i>Rotation 2</i>           |      |
| <i>Rotation 3</i>           |      |
| <i>Rotation 4</i>           |      |
| <i>Rotation 5</i>           |      |
| <i>Rotation 6</i>           |      |
|                             |      |
| <i>WATER CYCLE</i>          |      |
| <i>Rotation 1</i>           |      |
| <i>Rotation 2</i>           |      |
| <i>Rotation 3</i>           |      |
| <i>Rotation 4</i>           |      |
| <i>Rotation 5</i>           |      |
| <i>Rotation 6</i>           |      |
|                             |      |
| <i>BUILD A PSYCHROMETER</i> |      |
| <i>Rotation 1</i>           |      |
| <i>Rotation 2</i>           |      |
| <i>Rotation 3</i>           |      |
| <i>Rotation 4</i>           |      |
| <i>Rotation 5</i>           |      |
| <i>Rotation 6</i>           |      |

# ACMP Youth Camp High School Student Assistant Sign-Up

**Note:** Use this form to designate student assistants at the Youth Camp stations. Since the rotations for all stations occur at the same time, be sure that students do not sign up for the same rotation number more than once.

| Station                                   | Name |
|---|------|
| <b><i>SCIENCE OBSERVATION NETWORK</i></b> |      |
| <b><i>Rotation 1</i></b>                  |      |
| <b><i>Rotation 2</i></b>                  |      |
| <b><i>Rotation 3</i></b>                  |      |
| <b><i>Rotation 4</i></b>                  |      |
| <b><i>Rotation 5</i></b>                  |      |
| <b><i>Rotation 6</i></b>                  |      |
|   |      |
| <b><i>INTRODUCTION TO STELLA</i></b>      |      |
| <b><i>Rotation 1</i></b>                  |      |
| <b><i>Rotation 2</i></b>                  |      |
| <b><i>Rotation 3</i></b>                  |      |
| <b><i>Rotation 4</i></b>                  |      |
| <b><i>Rotation 5</i></b>                  |      |
| <b><i>Rotation 6</i></b>                  |      |
|   |      |
| <b><i>THE VIEW FROM SPACE (GINA)</i></b>  |      |
| <b><i>Rotation 1</i></b>                  |      |
| <b><i>Rotation 2</i></b>                  |      |
| <b><i>Rotation 3</i></b>                  |      |
| <b><i>Rotation 4</i></b>                  |      |
| <b><i>Rotation 5</i></b>                  |      |
| <b><i>Rotation 6</i></b>                  |      |

## Passports

At the beginning of the Youth Camp Day, give each visitor (students and community members) a blank passport. As visitors attend each station, the teacher or aide running the station should check off the appropriate box on their passport. Student assistants who are helping lead stations also qualify for a check mark for that station.

Youth Camp participants who complete a minimum of five stations are eligible to win a prize. A designated teacher should collect the passports at the end of the Youth Camp and mail any that have five or more stations completed to the Geophysical Institute. A prize will be sent back to those who have completed five or more stations!

# PASSPORT

## Youth Camp Stations

- Build an Anemometer
- Build a Weather Vane
- Build a Thermometer
- Water Cycle
- Build a Psychrometer
- Clouds as Art
- Science Observation Network
- STELLA Program
- GINA Program

Name: \_\_\_\_\_

# PASSPORT

## Youth Camp Stations

- Build an Anemometer
- Build a Weather Vane
- Build a Thermometer
- Water Cycle
- Build a Psychrometer
- Clouds as Art
- Science Observation Network
- STELLA Program
- GINA Program

Name: \_\_\_\_\_

# PASSPORT

## Youth Camp Stations

- Build an Anemometer
- Build a Weather Vane
- Build a Thermometer
- Water Cycle
- Build a Psychrometer
- Clouds as Art
- Science Observation Network
- STELLA Program
- GINA Program

Name: \_\_\_\_\_

# PASSPORT

## Youth Camp Stations

- Build an Anemometer
- Build a Weather Vane
- Build a Thermometer
- Water Cycle
- Build a Psychrometer
- Clouds as Art
- Science Observation Network
- STELLA Program
- GINA Program

Name: \_\_\_\_\_

# Build a Thermometer

Youth Camp



This station is to be led by an elementary school teacher or aide, with assistance from students. Repeat this station at least six times during Youth Camp day. All materials except for thermometer cards should be reused for each rotation. There are enough materials provided for six thermometers to be built during each rotation. Visitors to the station may need to work in pairs or groups.

## Station Preparation:

1. Copy the template “Thermometer Cards” and cut out 42 cards, since new thermometer cards will be needed for each rotation. Set out enough worksheets and pencils for each visitor.
2. Insert plastic tubes into rubber stoppers, positioning the stoppers about two-thirds of the way down the tubing.
3. Set out the actual thermometer for later comparison.
4. Fill a pitcher with water, and allow it to set until it is room temperature. Before each rotation, fill each beaker with 200 ml water using the room temperature water in the pitcher. Add four drops of food coloring to each beaker and stir.
5. Fill a separate pitcher with warm water (~90° F). Refresh the water in this pitcher throughout the day to ensure there is warm water during every rotation.
6. Set out the materials to build six thermometers. Each thermometer will require a glass beaker with room temperature water, plastic tubing, rubber stopper, thermometer card, tape, pencil and bowl.

## Demonstration Instructions:

1. Explain to visitors that during this activity they will build a thermometer. A thermometer is an instrument that measures temperature (how hot or cold something is).
2. Using the Student Instruction Sheet: “Build a Thermometer” as a guide, lead visitors through the process of building thermometers. *Note: When assembling the thermometers, gently push the black rubber stopper down until the water in the tube rises about an inch above the stopper. Create an airtight seal so the water level in the tube remains constant.*
4. After visitors finish their thermometers, instruct them to mark the water level in the tube on the left side of their cards in column 1.
5. Explain that the water level in the tube will rise if the thermometer gets warmer (just like a regular bulb thermometer). Demonstrate by placing the thermometers in a bowl of warm (~90° F) water. *Note: the water will bubble out the top of the tubing if the water is too hot.* Visitors should mark the water level in the thermometer tube on the right side of their cards in column 2.
6. Have visitors complete the worksheets, collect the worksheets in the packet provided and return them to the Geophysical Institute.

## Materials:

- Actual thermometer
- 2 pitchers
- Glass beakers
- Plastic tubing (about 12 inches long)
- Rubber stoppers (with holes sized to fit tubing)
- Water (room temperature and warm)
- Bowls
- Red food coloring
- Transparent tape
- Pencils
- STUDENT INSTRUCTION SHEET
- STUDENT WORKSHEET
- TEMPLATE: “Thermometer Cards”

# Build a Thermometer

---

## Student Instruction Sheet

Youth Camp

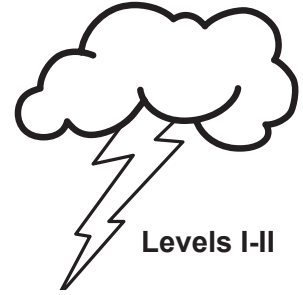

You will need:



Beaker



Plastic Tube  
and Plug

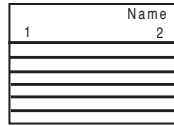

Card



Tape

Make a thermometer:



1.

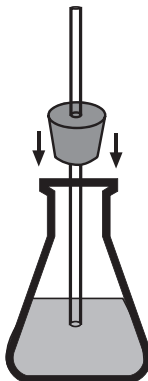

Put the plug in the beaker.

2.

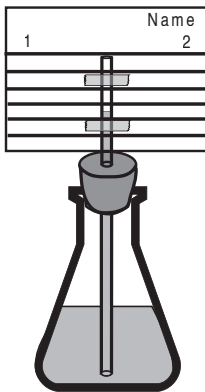

Tape the card to the tube.

# Template: Thermometer Cards

Each thermometer card template consists of a dashed rectangular border. On the left side, there is a vertical line labeled '1' at the top and '2' at the bottom. On the right side, there is a vertical line labeled '2' at the top and '1' at the bottom. In the center, there is a horizontal dashed line labeled 'tape tube here'. Below this line, there are ten vertical lines representing the thermometer scale. To the left of the scale, there is a label 'Name:' followed by a horizontal line for writing a name.

Name: \_\_\_\_\_

# Student Worksheet

## Build a Thermometer

Youth Camp

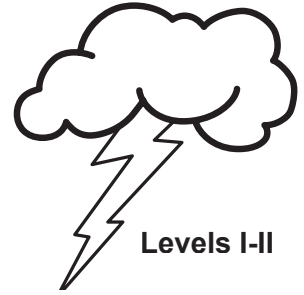

1. Circle the thermometer that shows a warmer temperature:

a.

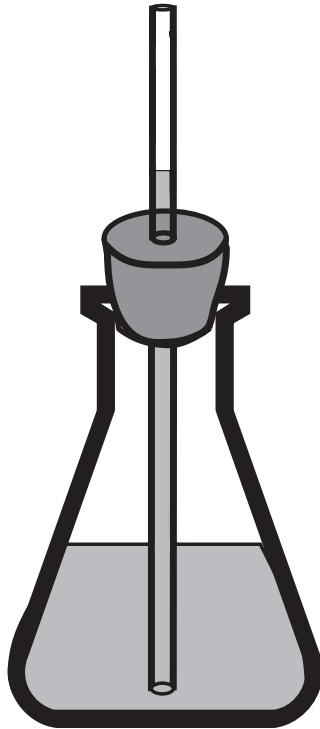

b.

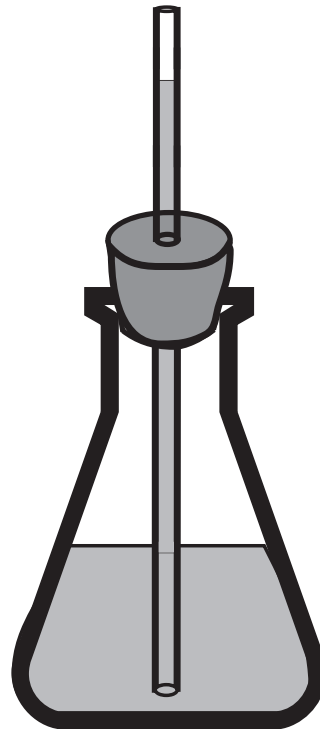

2. Look at the actual thermometer at the station. What is the temperature of the room?

# Build an Anemometer

---

Youth Camp

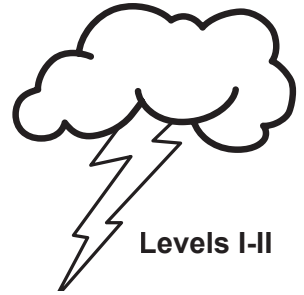

This station is to be led by an elementary school teacher or aide, with assistance from students. Repeat this station at least six times during Youth Camp day. Enough materials for 42 anemometers have been supplied (six anemometers per rotation, for a possible seven rotations). Have visitors to the station work in groups or pairs if necessary.

## Station Preparation:

1. Before each rotation, set out enough supplies for six anemometers. Each anemometer requires 4 flexible straws, 4 condiment cups, 2 balsa wood squares, 1 pencil with eraser, 1 washer, 1 T-pin, and 1 sticker. Set out the Student Instruction Sheets as well.
2. Copy and set out enough worksheets for each visitor to fill out. Be sure to provide pencils.

## Demonstration Instructions:

1. Explain to visitors that they will build a model anemometer. An anemometer is an instrument that measures how fast the wind is blowing.
2. Using the Student Instruction Sheet: "Build an Anemometer," guide the visitors through making their anemometers. Allow visitors to complete each step before continuing.
3. Designate one person to run the fan, and one to use the stopwatch.
4. Ask visitors to figure out the wind speed of the fan using the actual anemometer.
5. Next, instruct visitors to use the model anemometers in front of the fan for 20 seconds and count how many times the anemometer spins. *Hint: count the number of time the smiley face sticker goes around.* Visitors should record this information on the worksheets. Collect worksheets in the packets provided and return them to the Geophysical Institute.

## Materials:

- Actual anemometer
- Flexible straws (4 per anemometer)
- Condiment cups (4 per anemometer)
- Balsa Wood (or heavy cardstock) cut to 1-1/2" squares (2 per anemometer)
- Pencils with flat erasers (1 per anemometer)
- Washers (1 per anemometer)
- T-pins, large (1 per anemometer)
- Smiley-face stickers (1 per anemometer)
- Fan
- Tape
- Stopwatch
- Pencils to fill out worksheets
- STUDENT INSTRUCTION SHEETS: "Build an Anemometer"
- STUDENT WORKSHEETS: "Build an Anemometer"

# Build an Anemometer

## Levels I-II Student Instruction Sheet (page 1 of 2)

Youth Camp

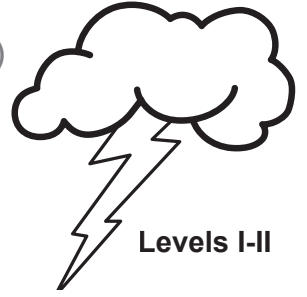

### You will need:



4 Straws



4 Cups



Tape



Sticker



Pin



Washer



2 Balsa Wood Squares

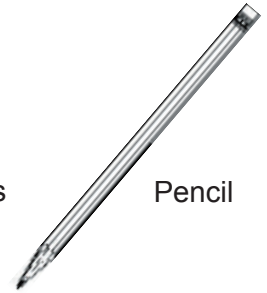

Pencil

### Make an Anemometer:

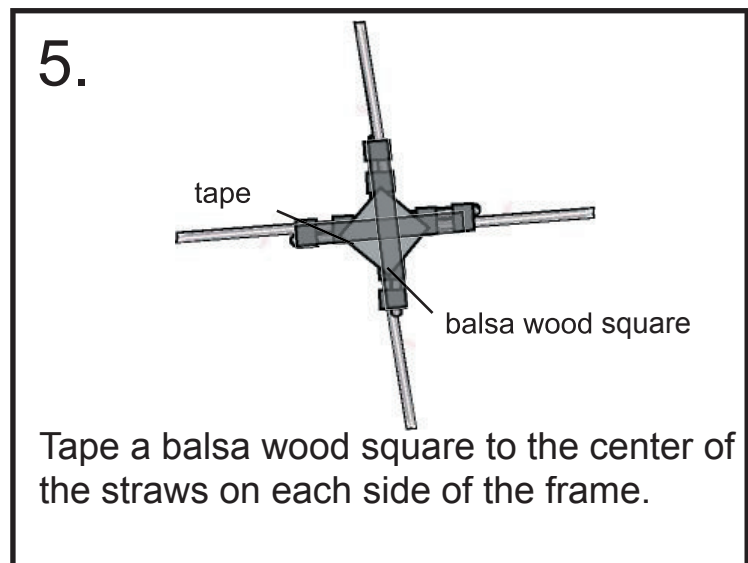
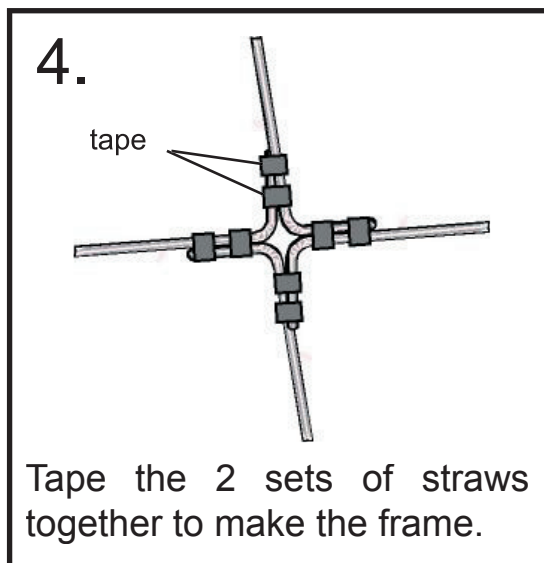
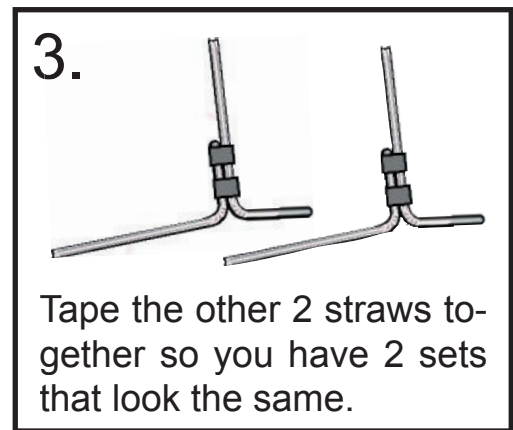
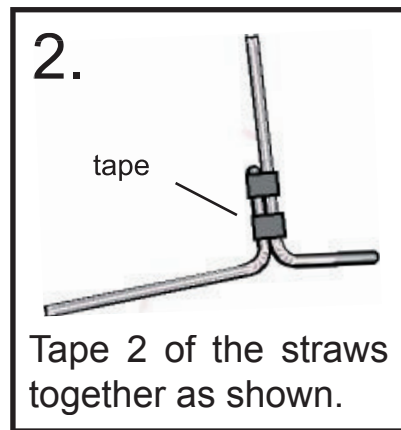
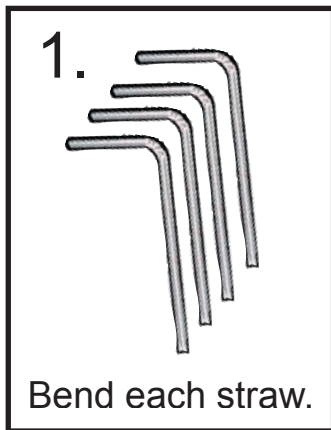

# Build an Anemometer

Levels I-II Student Instruction Sheet (page 2 of 2)

Youth Camp

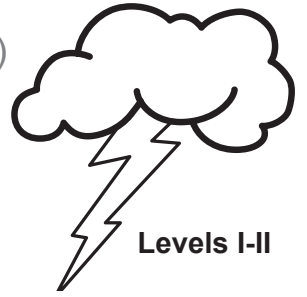

6.

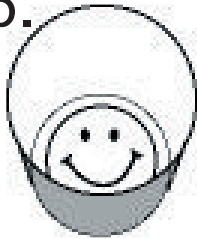

Put a sticker in the bottom of 1 cup.

7.

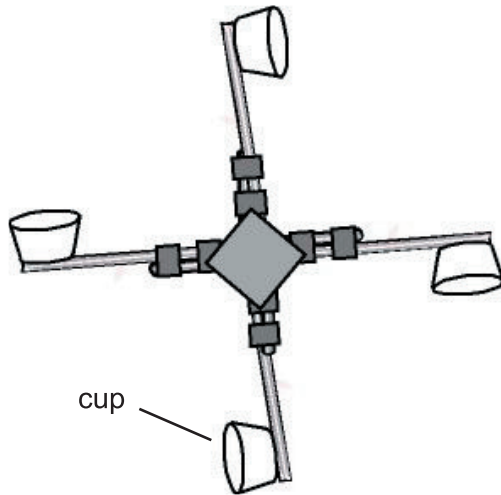

Tape 1 cup to the end of each straw. Make sure each cup is pointing the right direction!

8.

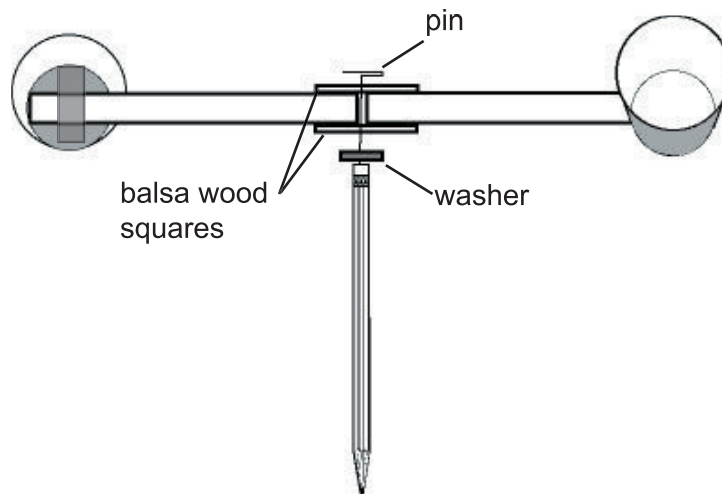

Poke the pin through the balsa wood squares in the center of the frame. Put the end of the pin through the washer, then push the pin into the pencil eraser.



# Build a Weather Vane

Youth Camp

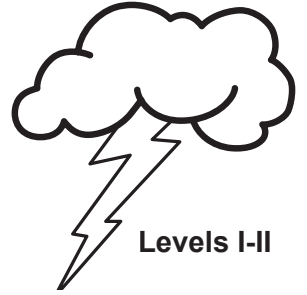

This station is to be led by an elementary school teacher or aide, with assistance from students. Repeat this station at least six times during Youth Camp day. Enough materials for 42 weather vanes have been supplied (six weather vanes per rotation, for a possible seven rotations). Have visitors to the station work in groups or pairs if necessary.

## Station Preparation:

1. Cut the index cards in half diagonally to make two “flags.” To cut evenly, use a ruler to draw a line from corner to corner as a guide. Create 42 flags (six per rotation, for a possible seven rotations).
2. Before each rotation, set out the materials to make six weather vanes. Each weather vane requires a thread spool, a straw, a skewer, an index card “flag,” and tape.
3. Using a compass, find north. Tape the Paper Compass to the table, oriented in the correct position. Place the fan on the table in any position, pointing toward the compass.
4. Set out enough worksheets and pencils for each visitor.

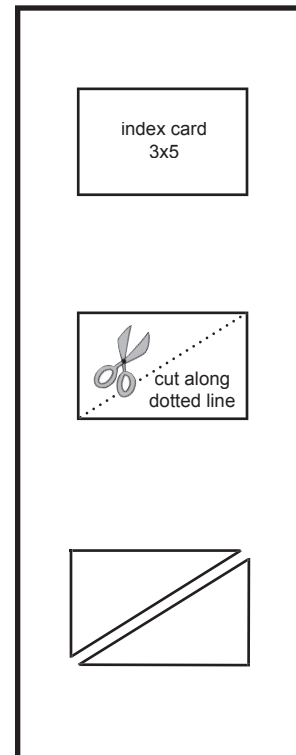

## Demonstration Instructions:

1. Explain to visitors that they will make model weather vanes. Weather vanes are instruments that show which way the wind is blowing.
2. Using the Student Instruction Sheet, guide visitors through making their model weather vanes.
3. When the weather vanes are complete, have visitors take turns setting their weather vanes in the center of the Paper Compass on the table. Turn the fan on, and see which way the flag on the weather vane points. If you wish, you may change the direction of the fan for each visitor.
4. Ask visitors to record which way their weather vane pointed on their worksheets. Collect the worksheets in the packet provided and return them to the Geophysical Institute.

## Materials:

- Index cards
- Ruler
- Scissors
- Paper Compass
- Thread spools (1 per weather vane)
- Straws (1 per weather vane)
- Transparent tape
- Skewers (1 per weather vane)
- Navigational compass
- Fan
- Pencils
- STUDENT INSTRUCTION SHEET: “Build a Weather Vane”
- STUDENT WORKSHEET: “Build a Weather Vane”

# Build a Weather Vane \_\_\_\_\_

## Student Instruction Sheet

Youth Camp



### You will need:



Straw



Tape

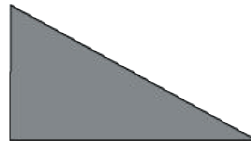

Flag



Skewer

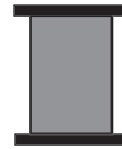

Spool

### Make a Weather Vane:

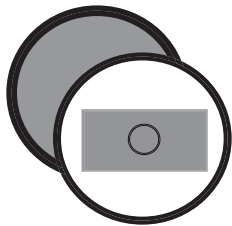

Cover one end of the spool with tape. This is the bottom.

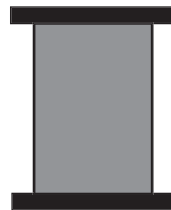

Stand the spool on its bottom (the end with the tape).

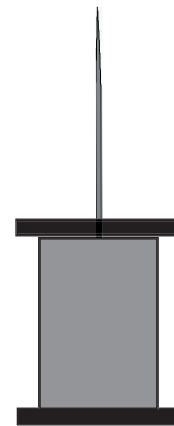

Put the skewer in the hole of the spool.

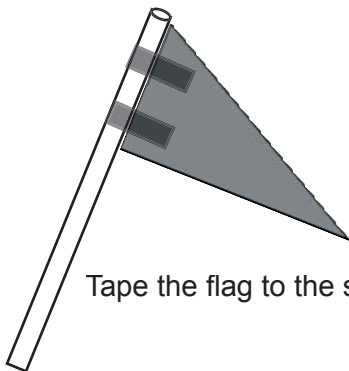

Tape the flag to the straw.

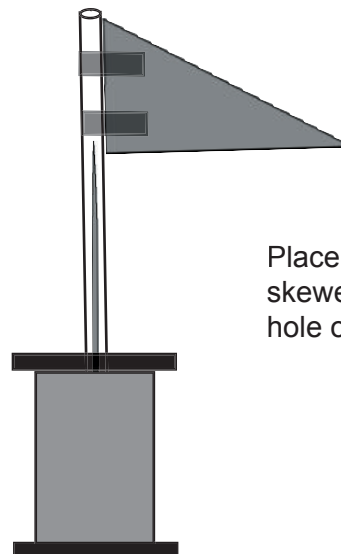

Place the straw over the skewer and through the hole of the spool.

# Paper Compass

Youth Camp

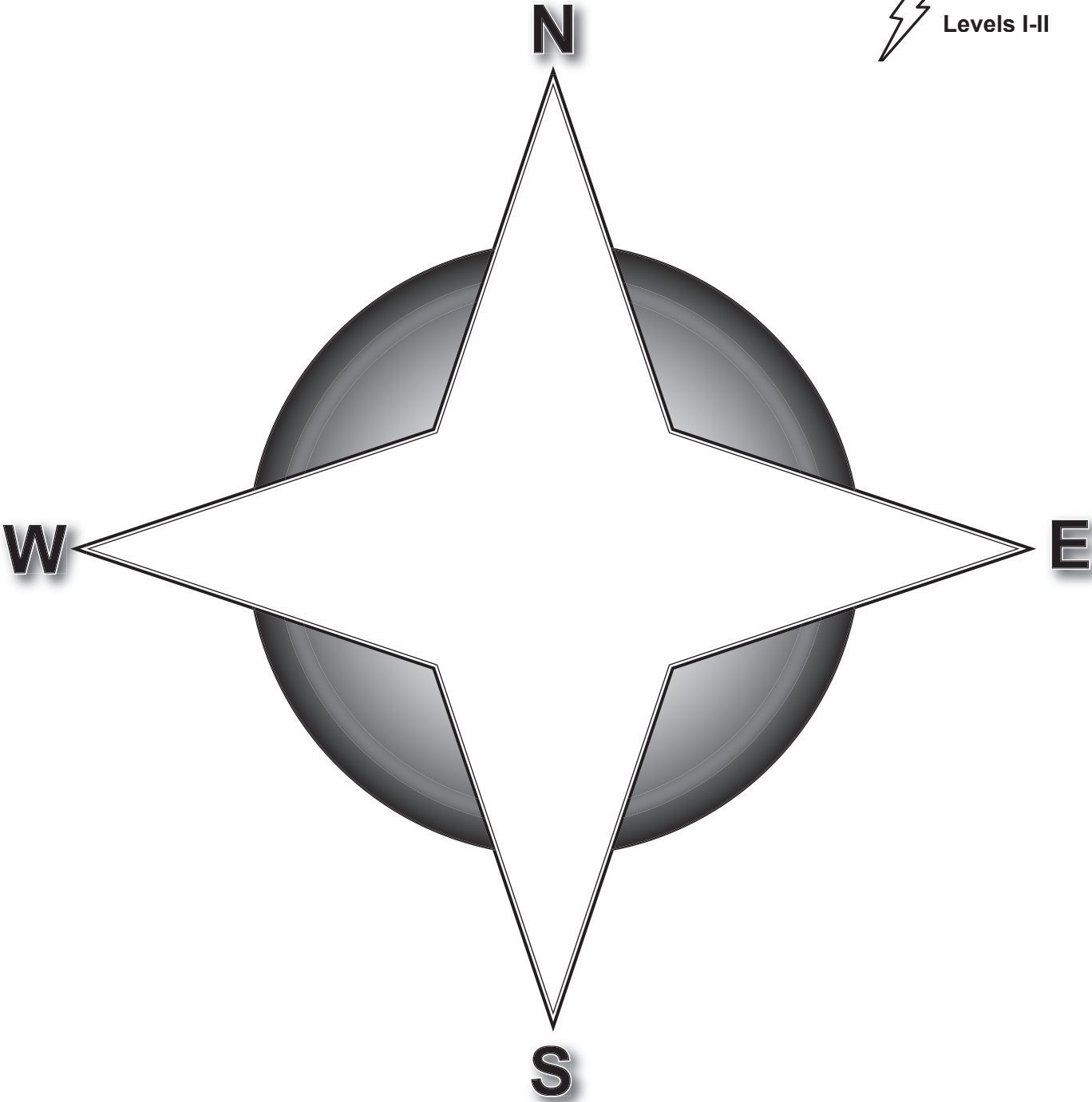

Name: \_\_\_\_\_

Student Worksheet  
Build a Weather Vane

Youth Camp

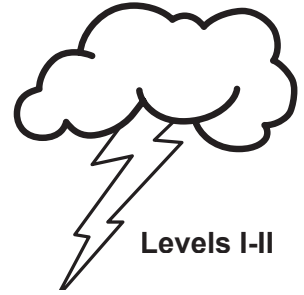

Draw an arrow showing which way the "wind" was blowing. (Hint: this should be the same as the direction your flag pointed.)

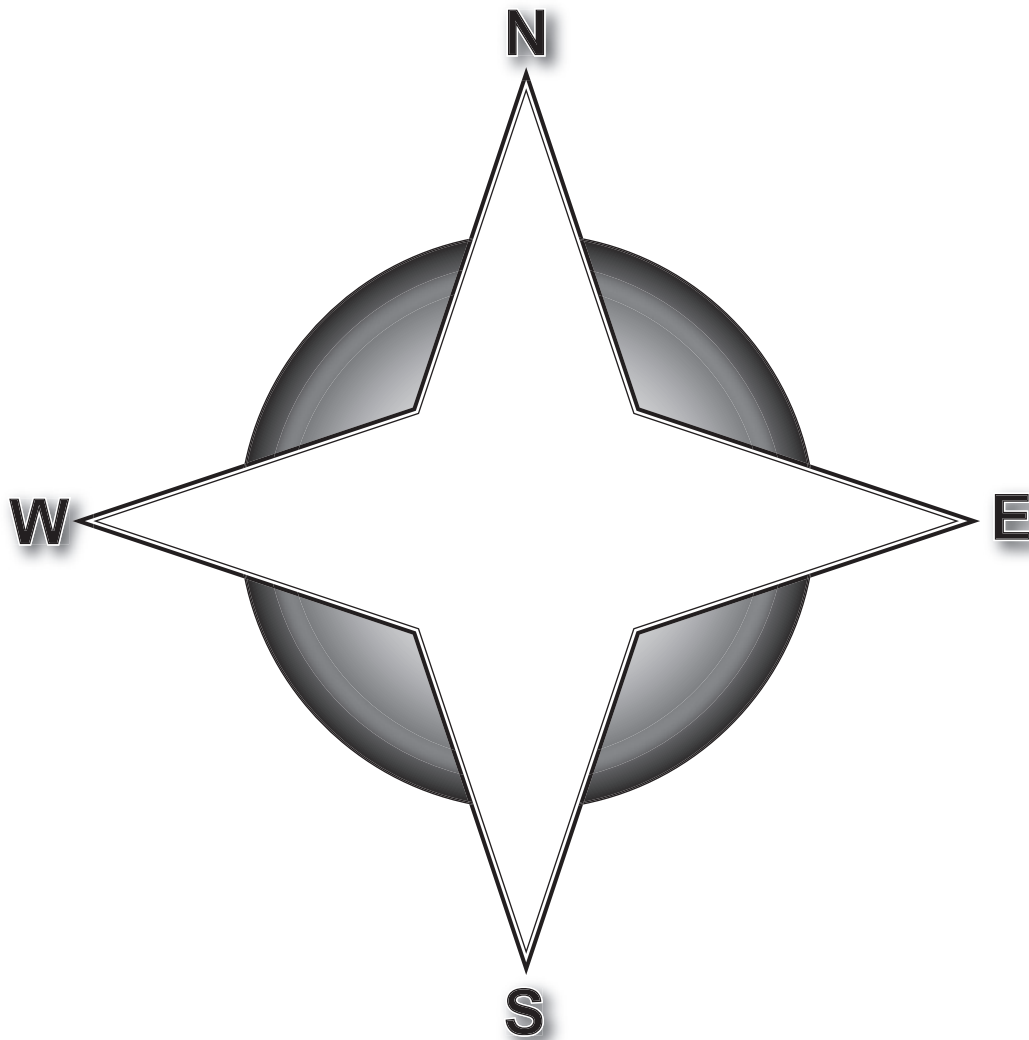

# Clouds As Art

---

Youth Camp

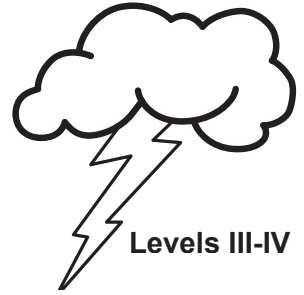

Note: This station should be set up near a wall.

This station is to be led by a middle school teacher or aide, with assistance from students. Repeat this station at least six times during Youth Camp day.

## Station Preparation:

1. Set out enough worksheets and pencils for each visitor to the station.
2. Set out the Clouds as Art diagrams and markers.
3. On a wall, create and label four columns of cloud types: stratus, cumulus, cumulonimbus and cirrus.

## Demonstration Instructions:

1. Ask visitors to the station to illustrate a cloud using markers on the worksheet.
2. Once they have completed their drawing, use the Clouds as Art diagrams and explanations to determine what kind of cloud each visitor drew.
3. Ask visitors to write the name of the cloud type they drew on their worksheet, then tape their art on the wall in the proper column.
4. Collect the worksheets in the packets provided and send them to the Geophysical Institute.

## Materials:

- Markers
- Tape
- Pencils
- STUDENT WORKSHEETS: "Clouds As Art"
- STUDENT INFORMATION SHEETS: "Clouds As Art Diagrams"

# Student Information Sheet (1 of 2)

## Clouds As Art Diagrams

Youth Camp

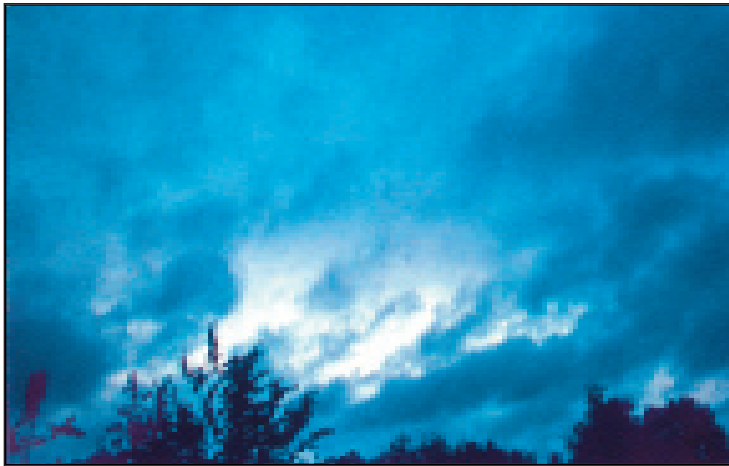
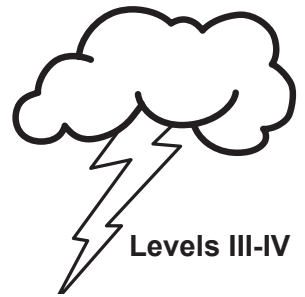

### **Stratus Clouds:**

*Stratus* clouds normally form only a few hundred feet above the ground. They are low, thin, billowy clouds that sometimes can be seen filling valleys. Fog is a stratus cloud. These clouds are usually seen in early morning or in late evening because the air often becomes still and calm at these times of the day.

### **Cumulus Clouds**

*Cumulus* clouds are fluffy white clouds that drift across the sky about one mile above Earth. These clouds look like cotton balls or popcorn. On a summer day, these clouds make fast-moving shadows across the ground. They increase in number and become larger as the sun reaches its warmest in the afternoon. By evening, they usually thin and flatten into stratus clouds. A large number of heavy, cumulus clouds often means rain is in the forecast.



# Student Information Sheet (2 of 2)

## Clouds As Art Diagrams

Youth Camp

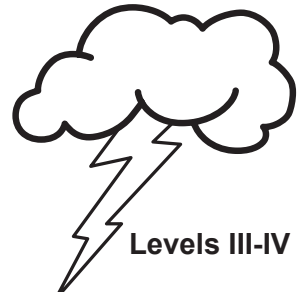

### **Cumulonimbus Clouds**

*Cumulonimbus* clouds are large clouds with dark lower edges and tall billowing towers. These clouds are sometimes called thunderheads because they often bring rain and thunder. Rain often hides the bottom of these dark gray clouds.

### **Cirrus Clouds**

*Cirrus* clouds are feathery, white clouds that float high above Earth. These wispy clouds are made up of ice crystals. They are the highest clouds in the sky, sometimes rising as high as 10 miles above Earth.

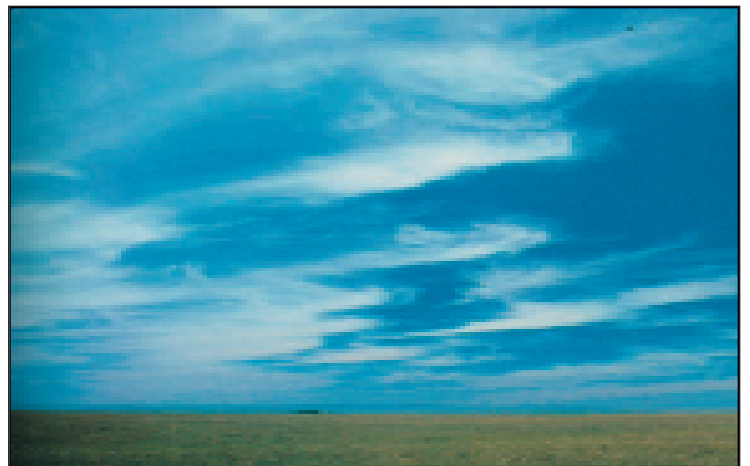

Name: \_\_\_\_\_

# Student Worksheet

## Clouds As Art

Youth Camp

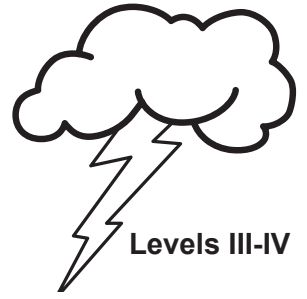

Draw a Cloud:

Cloud Type: \_\_\_\_\_

# Water Cycle

---

Youth Camp



Note: this station requires some preparation at least 24 hours in advance.

This station is to be led by a middle school teacher or aide, with assistance from students. Repeat this station at least six times during Youth Camp day. Enough materials for 42 water cycle activities have been supplied (six water cycle bags per rotation, for a possible seven rotations). Have visitors to the station work in groups or pairs if necessary.

## Station Preparation:

1. The day before the Youth Camp, ask students to assemble a sample of the Water Cycle Bag. They can do this by following steps 1-5 on the Water Cycle Activity Instruction Sheet. Students should affix the bag to a south-facing window. This way, students can show visitors to the Water Cycle station what happens to water in the bags over the course of a day.
2. Before each rotation, set out the materials needed to build the Water Cycle Bag. There are enough materials for six water cycle bags to be assembled for seven station rotations. Set out a few Water Cycle Student Information Sheets for reference.
3. Fill the pitcher with water and add drops of food coloring until the water is red.
4. Set out enough worksheets and pencils for every visitor to the station.

## Demonstration Instructions:

1. When it is time to demonstrate how to make the water cycle bag, ask visitors to use a marker to write their name on a Ziploc bag. If needed, have visitors divide into pairs or groups.
2. Ask visitors fill a clear plastic cup half full with colored water from the pitcher, and mark the level of the water in the cup (with a marker on the side of the cup). The cups of water represent oceans, rivers and lakes.
3. Visitors should then place the cups in the bags, being careful not to spill the water into the bags. Show the visitors how to hold the bag by one corner so the cup nests into the bottom corner of the bag. The bag represents the atmosphere and air.
- 4.. Next, seal the bag. Be sure to leave some air inside the bag.
5. Using a piece of duct tape about three inches long, ask visitors to affix their bags to a south-facing window with the cup nested upright in the lowest corner. Leave the bag in the sun for the rest of the day.
6. After several hours, some water from the cup should evaporate and condense on the bag, and will then roll down and pool in the bottom of the bag. Show the visitors the Water Cycle Bag that students assembled ahead of time. Look to see if the level of water in the cups is lower. The water on the sides and in the bottom of the bag represent rain.
7. Explain that the water from the cups (representing lakes, rivers, oceans) evaporates into the air in the bag and condenses on the bag. It then runs down inside the bag to the bottom of the bag (representing rain, snow or other precipitation).
8. Show the Water Cycle Student Information Sheet to the visitors and ask student assistants to help explain how the water cycle works. Cover each of the steps of the cycle highlighted on the following page.



## **Evaporation:**

When the sun warms the surface of a large body of water, such as an ocean or lake, water is added to the atmosphere by a process called evaporation. Evaporation causes water to change phase from liquid to invisible water vapor.

## **Condensation:**

Once water is in the atmosphere and temperatures cool, water vapor molecules stick to tiny particles floating in the air. This is called condensation. After many water vapor molecules condense on one tiny particle, a droplet of liquid water forms. A group of droplets form a cloud.

## **Precipitation:**

As temperatures get colder, cloud droplets become larger. When a drop becomes too heavy to float in the air, it falls as rain or snow through a process called precipitation. When this liquid reaches Earth, it can soak into the ground, collect in oceans and lakes, runoff as rivers or streams, or freeze into glaciers or ice sheets.

9. Ask visitors to complete the questions on their worksheets. Collect the worksheets in the packets provided and return them to the Geophysical Institute.

## **Materials:**

- Gallon-size Ziploc bags
- Marker pens
- 8 oz. clear Dixie cups
- Red food color
- Water (4 oz. per cup)
- Pitcher for colored water
- Strong duct tape (that will stick to the window)
- South-facing window
- Pencils
- STUDENT INFORMATION SHEET: "Water Cycle"
- STUDENT INSTRUCTION SHEETS: "Water Cycle Bag"
- STUDENT WORKSHEETS: "Water Cycle"

# Water Cycle Bag \_\_\_\_\_

---

## Student Instruction Sheet

Youth Camp

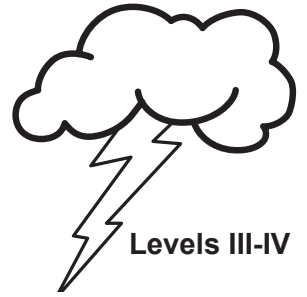

### Materials:

- Gallon-size Ziploc bag
- Marker pen
- 8 oz. clear Dixie cup
- Colored water (4 oz. per cup)
- Strong duct tape (that will stick to the window)
- South-facing window
- Pencil

### Procedure:

1. Fill a clear plastic cup half full with colored water, and use a marker to mark the water level on the outside of the cup.
2. Place the cup upright in the bottom corner of the Ziploc bag, and hold the bag by one corner so the cup does not spill. It is important not to spill the water into the bag.
3. Seal the bag, making sure to leave some air space inside the bag.
4. Using a piece of duct tape, about three inches long, affix the bag to a south-facing window with the cup nested upright in the lowest corner. Leave the bag in the sun for the rest of the day.
5. After several hours, some water from the cup should evaporate and condense on the bag, and will then roll down and pool in the bottom of the bag. Look to see if the level of water in the cup is lower. This represents the water cycle.

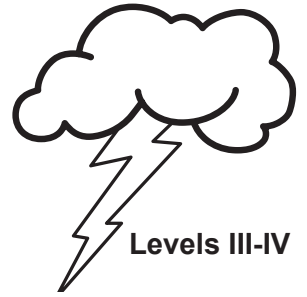

Levels III-IV

# Water Cycle

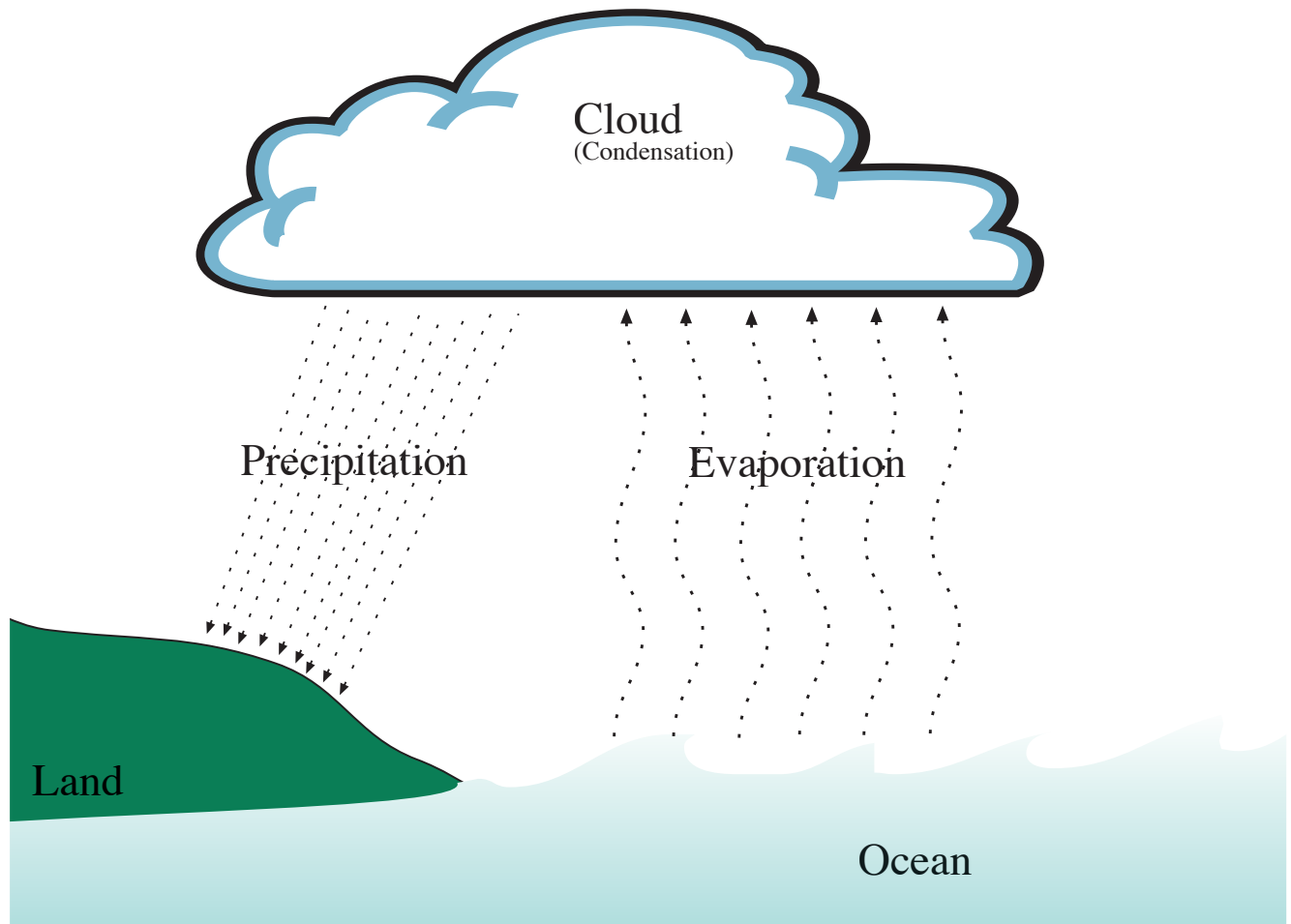

Name: \_\_\_\_\_

Student Worksheet  
Water Cycle

Youth Camp

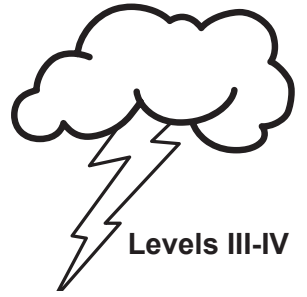

Label the three main water cycle processes below:

# Water Cycle

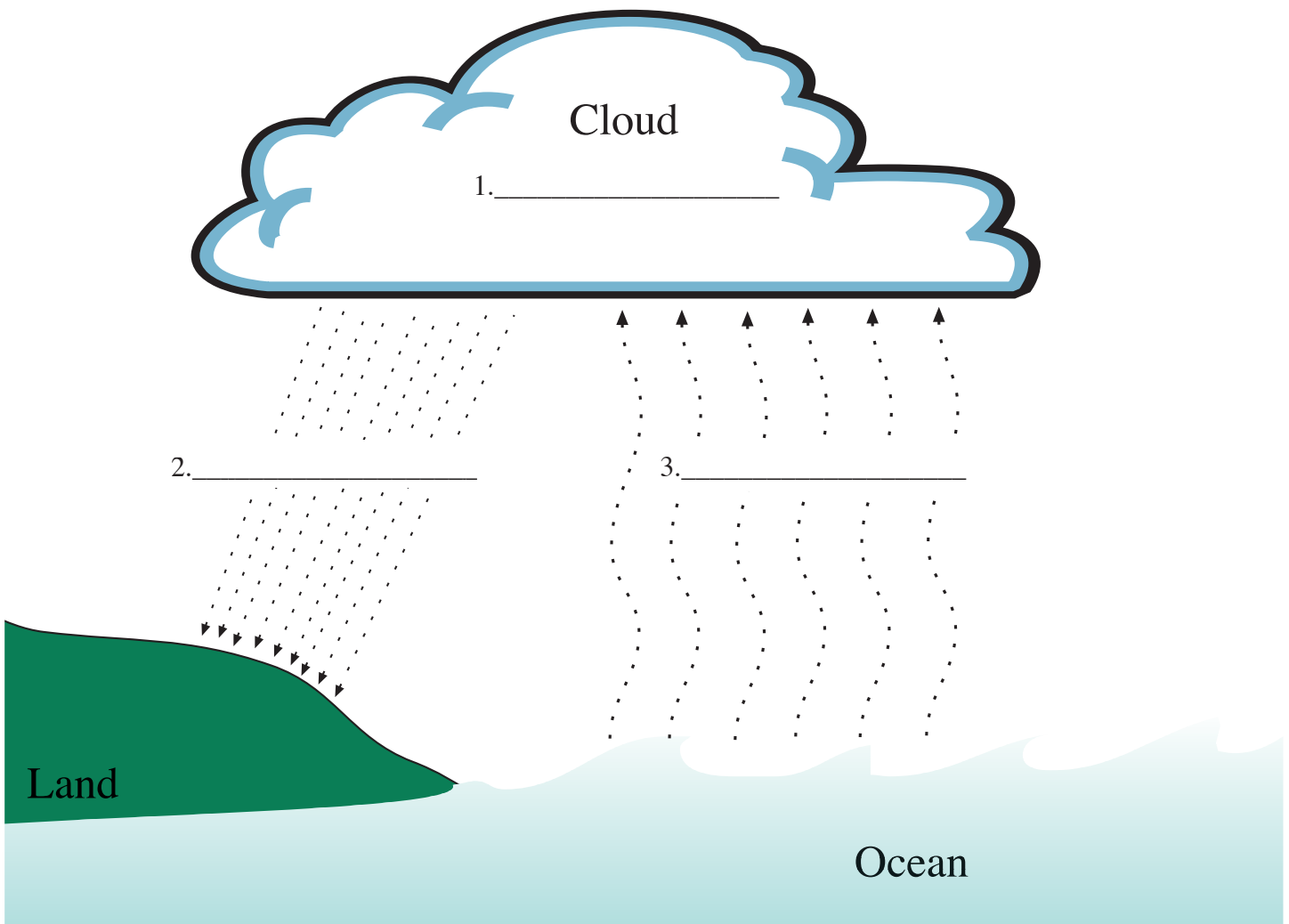

# Build a Psychrometer

---

Youth Camp

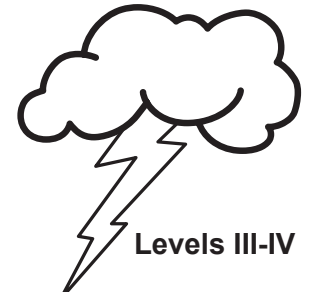

This station is to be led by a middle school teacher or aide, with assistance from students. Repeat this station at least six times during Youth Camp day. Enough materials have been supplied to make six psychrometers at every rotation, for a possible seven rotations. The materials will be reused for each rotation, with the exception of the muslin. Ask visitors to the station to work in groups or pairs if necessary.

## Station Preparation:

1. Before each rotation, set out the materials needed to build six psychrometers as well as some Student Instruction and Information Sheets. Each psychrometer requires 2 bulb thermometers (the thermometers should be reading the same temperature), 1 piece of muslin fabric, 1 small container, 1 rubber band, 1 piece of heavy paper and water.
2. Set out enough worksheets and pencils for every visitor to the station.
3. After each rotation, collect the wet muslin fabric strips and replace with dry muslin strips.

## Demonstration Instructions:

1. Explain that visitors to this station will be building psychrometers (si-kraw-meters). They are special instruments used to measure the humidity of the air. Psychrometers have two bulb thermometers. One bulb is wet and the other is dry. The wet bulb helps determine the relative humidity.
2. Assist visitors with building psychrometers. Make sure the two thermometers for each psychrometer are reading exactly the same temperature. If they are not, try to trade with others.
3. On one bulb thermometer, wrap a piece of muslin fabric around the bulb. Fasten it with a rubber band so the muslin trails out about three inches.
4. Fill the small container with water and wet the muslin that is attached to the thermometer. It will act as a wick and carry water to the bulb.
5. Lay the two thermometers side by side on the table, leaving the muslin trailing into the water. When the water wicks up to the bulb (after about five minutes) start fanning both thermometers with a piece of heavy paper.
6. When the wet-bulb temperature is steady (after about 5 minutes), write down both readings in degrees Fahrenheit.
7. Instruct visitors to complete the Student Worksheets. Assist them with using the Relative Humidity Table. Collect the worksheets in the packet provided and return them to the Geophysical Institute.

**Note:** Ask visitors what feels colder: a bare dry hand outside or a bare wet hand outside. Explain that the wet hand is colder because the water is evaporating from their hand and causing a cooling effect. This is the same reason a psychrometer works. If the humidity were 100% both bulbs would be the same temperature and both hands would be the same temperature.

## Materials:

- Bulb thermometers (2 per psychrometer)
- Muslin fabric pieces (1 per psychrometer)
- Small containers (1 per psychrometer)
- Water
- Rubber Bands (1 per psychrometer)
- Pieces of heavy paper for fanning (1 per psychrometer)
- Pencils
- STUDENT INSTRUCTION SHEETS
- STUDENT WORKSHEETS
- STUDENT INFORMATION SHEETS

# Build a Psychrometer

---

## Student Instruction Sheet

Youth Camp

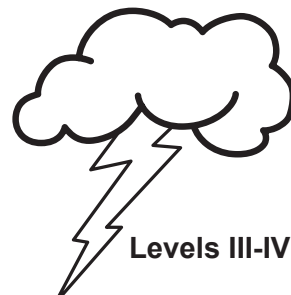

### Materials:

- 2 bulb thermometers
- 1 piece of muslin fabric
- Small container
- Water
- Rubber band
- Piece of heavy paper for fanning
- Pencil

### Procedure:

A psychrometer (si-kraw-meter) is an instrument for measuring moisture in the air. It has a wet and dry bulb thermometer. The wet bulb helps determine the relative humidity.

1. Select two thermometers that are reading exactly the same temperature.

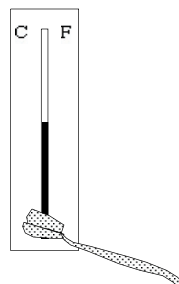

2. On one thermometer wrap a piece of muslin around the bulb. Fasten it with a rubber band so that the muslin trails out about three inches.

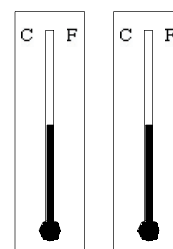

lin

3. Fill the small container with water and wet the muslin that is attached to the thermometer. It will act as a wick and carry water to the bulb.

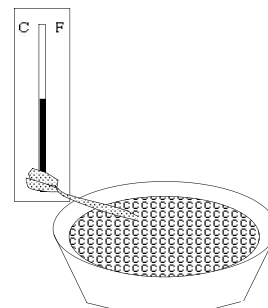

4. Lay the two thermometers side by side on the table, leaving the muslin trailing into the water. When the water wicks up to the bulb (after about 5 minutes) start fanning them with a paper.

5. When the wet-bulb temperature is steady (after about 5 minutes) write down both readings in degrees Fahrenheit.

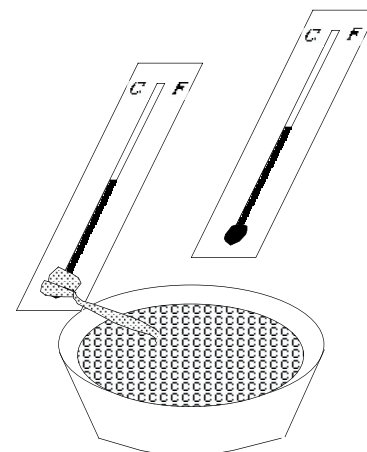

6. Use the Relative Humidity Table and the worksheet to help convert your recorded temperature readings into Relative Humidity.

Name: \_\_\_\_\_

Student Information Sheet  
Build a Psychrometer



Relative Humidity Table:

| Column I                                     | Column II                | Column III                         |
|--|--------------------------|------------------------------------|
| DRY-BULB<br>MINUS<br>WET-BULB<br>TEMPERATURE | DRY-BULB TEMPERATURE     | RELATIVE<br>HUMIDITY<br>IN PERCENT |
|  | 30 40 50 60 70 80 90 100 |                                    |
| 0  |                          | 100                                |
| 1  |                          | 90                                 |
| 2  |                          |                                    |
| 3  |                          |                                    |
| 4  |                          | 80                                 |
| 5  |                          |                                    |
| 6  |                          |                                    |
| 7  |                          | 70                                 |
| 8  |                          |                                    |
| 9  |                          |                                    |
| 10   |                          | 60                                 |
| 12   |                          |                                    |
| 14   |                          | 50                                 |
| 16   |                          |                                    |
| 18   |                          | 40                                 |
| 20   |                          |                                    |
| 25   |                          | 30                                 |
| 30   |                          | 20                                 |
| 35   |                          | 10                                 |
| 40   |                          | 5                                  |
| 45   |                          | 0                                  |

Name: \_\_\_\_\_

# Student Worksheet

## Build a Psychrometer



To find the relative humidity, follow these directions:

1. Write down the Fahrenheit temperature of the dry bulb thermometer.  
(a) \_\_\_\_\_ ° F
2. Write down the Fahrenheit temperature of the wet bulb thermometer.  
(b) \_\_\_\_\_ ° F
3. Subtract the wet bulb temperature from the dry bulb temperature.  
(a) – (b) = (c) \_\_\_\_\_ ° F
4. Find the number on the first column of the Relative Humidity Table that matches (c). (*Hint: This is your answer to question #3 above*).
5. Find the dry bulb temperature that matches the (a) reading. (*Hint: This is your answer to question #1 above*.) Put one finger on the “dry bulb temperature” column and one finger on the “dry bulb minus wet bulb temperature” column.
6. Trace your fingers from left to right and top to bottom until they meet. Put an ‘x’ on this spot in the chart. Determine if your ‘x’ is in a black or gray ribbon or wave on the chart.
7. Follow the ribbon or wave that contains your ‘x’ to the “relative humidity in percent” column.
8. What is the relative humidity of the air in the room?

# Introduction to the Science Observation Network

---

Youth Camp

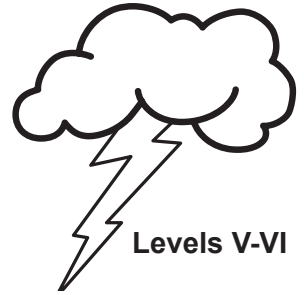

This station is to be led by a high school teacher or aide, with assistance from students. Repeat this station at least six times during Youth Camp day.

## Station Preparation:

1. Set up a computer on a table and connect the computer to a power source. Or, if possible, bring visitors to a computer lab or classroom with computers.
2. Insert "Introduction to the Science Observation Network" CD-ROM into the computer. Select "No-Internet" and then "entry\_cd-rom.swf"
3. Navigate through the interactive CD-ROM a few times to become familiar with it.
4. Set out enough worksheets and pencils for every visitor to the station.

## Demonstration Instructions:

1. Explain to visitors that weather information from schools in the Bering Strait School District will be available on the Internet on the Science Observation Network.
2. Explain that students will be able to input and access weather information from the network and will be able to manipulate the data in charts and graphs. Students also will be able to compare the weather in different BSSD villages.
3. Explain that a sample CD-ROM will be used at the station for demonstration purposes. The information on the CD-ROM is from October 21, 2005. It is just a sample, but will demonstrate the capabilities of the Science Observation Network.
4. Select "Enter Data" from the main page. Select a village and click "Guest" to show visitors how students will enter data into the Science Observation Network.
5. Allow visitors to explore the CD-ROM.
6. Ask visitors to complete the worksheet using information from the CD-ROM. Collect worksheets in the packet provided and return them to the Geophysical Institute.

## Materials:

- ACMP Science Observation Network CD-ROM
- Computer(s)
- Pencils
- STUDENT WORKSHEET: "Introduction to the Science Observation Network"

Name: \_\_\_\_\_

## Student Worksheet

# Introduction to the Science Observation Network



Directions: From the main page of the ACMP Science Observation Network CD-ROM, select "View Data." Then, select "Show all Weather Stations."

1. Which village had the coldest temperature?

2. Which village was windiest?

# Computer Modeling: Introduction to STELLA

Youth Camp

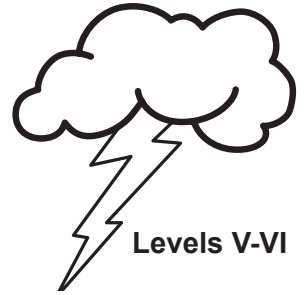

This station is to be led by a high school teacher or aide, with assistance from students. Repeat this station at least six times during Youth Camp day.

## Station Preparation:

1. Place a laptop or desktop computer on a table, and connect the computer to a power source. Or, if possible, bring visitors to a computer lab or classroom with computers
2. Insert the “Introduction to STELLA Animation CD” CD-ROM into the computer, and run through the interactive CD-ROM a few times to become familiar with the language of STELLA.
3. Read the Student Information Sheet: “STELLA Modeling Introduction” to better understand how STELLA can be used in the classroom, and what is meant by the “language” of computer modeling.
4. Set out enough worksheets and pencils for every visitor to the station.

## Demonstration Instructions:

1. Explain to visitors that scientists use computers to create models which predict changes to a system occurring over time. For example, meteorologists (people who study weather) make weather predictions based on computer models. These models use information like wind currents, humidity, wind speed and temperature to determine what the weather is likely to be in the days and weeks ahead. Some models contain huge amounts of data and require large computers to run, such as models used to determine the movement of stars in the night sky, or to track satellites as they orbit Earth. Ask visitors if they can name any other examples of computer models (examples may include: models of human population growth, earthquake impacts, and fish run predictions).
2. Explain that STELLA is a computer model that can be run on a desktop computer. It is used to describe and test how a system, such as a watershed, might respond to change. Through careful programming, it will run mathematical formulas and give probable outcomes based on the information that is entered into it.
3. Assist visitors in using the CD-ROM so they become familiar with the language of STELLA, and provide an overview of the language of computer modeling based on the Student Information Sheet: “STELLA Modeling Introduction.”
4. Ask visitors to complete the worksheet. Collect worksheets in the packet provided and return them to the Geophysical Institute.

## Materials:

- STELLA Introduction Animation CD-ROM
- Desktop or laptop computer
- Pencils
- STUDENT INFORMATION SHEET: “STELLA Modeling Introduction”
- STUDENT WORKSHEET: “STELLA Modeling Introduction”

# STELLA Modeling Introduction

---

## Student Information Sheet

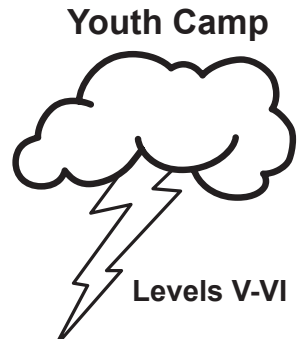

**Scientists use a variety of methods to predict change over time.** If a scientist wants to predict winter storms, they study satellite images, barometric pressure readings, wind speed, and so on. When scientists have a lot of data to work with, they often use computer models to help them make sense of their data.

**STELLA is a computer modeling program** used by students, teachers, and researchers to create models that predict change over time.

**Writing a computer model is a lot like writing a mystery.** The author must include information about all the factors which lead to the story's conclusion. If these factors are changed, the conclusion of the story may change. A well-written computer model can predict how change in one or more factors will impact the outcome.

### **EXAMPLE:**

A scientist studying decline in the local fish population can use computer modeling to help her determine how various factors impact fish population. To do this, she must research information about each factor and write this information into her computer model. Important factors may include historic fish population numbers, current fish population numbers, and anything that affects population numbers, like commercial and subsistence fishing, water temperatures, and aquatic food supply. Once enough information about each factor known to affect fish population is entered into the computer model, the model can adjust variables associated with different factors to see what effect they may have on fish populations. In this example, the computer model may indicate that an increase in water temperature by 2 degrees Fahrenheit likely will cause a 20% reduction in egg survival.

**To work with the STELLA computer modeling program, start by learning the “language.”** This means learning the symbols used to tell the story. STELLA uses a simple language of rectangles and arrows. The rectangles contain all “subjects” within the story line while arrows indicate the “action” or connections between these subjects.

**To become familiar with the STELLA language use the “Introduction to STELLA Animation CD-ROM.”**

Name: \_\_\_\_\_

## Student Worksheet

# STELLA Modeling Introduction

Youth Camp

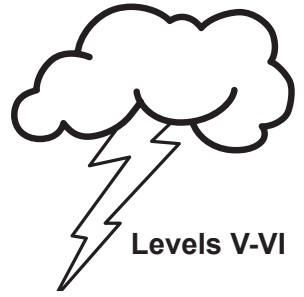

Levels V-VI

1. Why do scientists use computer modeling programs?

---

---

---

---

2. What important population decline or environmental problem should students study in the Bering Strait region?

---

---

---

---

# The View from Space (GINA)

---

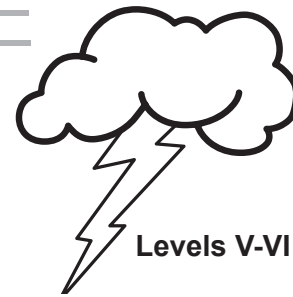

This station is to be lead by a high school teacher or aide, with student assistance. Repeat this station at least six times during Youth Camp day.

## Station Preparation:

1. Set up a computer on a table and connect the computer to a power source and the Internet. Or, if possible, bring visitors to a computer lab or classroom with computers.
2. Follow the instructions on the Student Instruction Sheet for accessing the GINA Website.
3. Set out enough worksheets and pencils for every visitor to the station.

## Demonstration Instructions:

1. Explain to visitors that GINA is the main resource for the University of Alaska's geospatial data, with online satellite images of Alaska, an advanced geographic information system (GIS), and topographic imaging that can be used to study the extent of fires in the state, the presence and extent of sea ice along the coast, channel movement in major river drainages, weather patterns, and much more.
2. Explain to visitors that they can go online and learn to navigate the GINA Website to study satellite images showing sea ice along the coast near their village. Ask visitors why it would be useful to see current satellite images of sea ice. Their answers should include: knowing where the ice is for safety during travel out onto the ice, and may include an interest in global warming and erosion affecting coastal villages.
3. Use the Student Information Sheet to demonstrate to visitors how to enter the GINA Website.
4. Point out to visitors that the top left of the map displays the latitude and longitude of the cursor as it is moved around the map.
5. Lead a demonstration showing how GINA can be used to study Norton Sound over time by following these steps:
  - a) Scroll down to 2005-01-27 at 21:22:41 GMT and click on this date and time. The cloudless satellite image clearly shows ice in the Bering Strait and Norton Sound.
  - b) Click on View again and scroll down to 2005-01-29 at 21:10:28 GMT. The ice has shifted to the east.
  - c) Scroll down to 2005-01-31 at 20:58:11 GMT to see further eastward movement.
  - d) Now scroll down to 2005-02-07 at 21:04:17GMT. Clouds obscure the sound.
  - e) Look at 2005-02-10 at 21:34:54GMT. The ice has moved back into the sound.
6. Ask visitors to complete the worksheet. Assist them in answering the questions. Collect all worksheets in the envelope provided and return them to the Geophysical Institute. Teacher Note: the answer to worksheet question number 1 is c) both.

## Materials:

- Computer(s) with Internet access
- Pencils
- STUDENT WORKSHEET: "A View from Space"
- STUDENT INFORMATION SHEET: "Instructions for Using GINA Online"

Name: \_\_\_\_\_

# Levels V-VI Student Information Sheet

## Instructions for using GINA Online

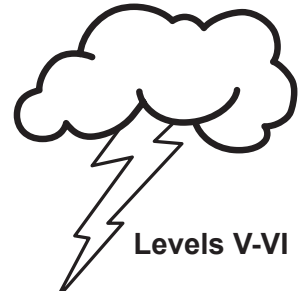

### Using the GINA System

1. Type in the URL for the GINA Web site: [www.gina.alaska.edu](http://www.gina.alaska.edu).
2. Click on Swathviewer on the upper right.
3. Click on linework on the upper left.
4. Click on U.S. cities at the bottom of the list to give it a checkmark.
5. Click on the "+" magnifying glass at the upper right of the page.
6. Use the mouse (the arrow will now look like a magnifying glass) until it is positioned over the Seward Peninsula. Click on it three times to zoom the satellite image up to 2 km above the peninsula (2 km will be highlighted on the ruler on the top left. Zooming in to 500 meters or closer may result in a loss of image. If this happens, use the mouse to zoom out by sliding the highlight to the left on the ruler).
6. Click on the Images bar on the upper left.
7. Click on the Misc bar and scroll down to select Terra-MODIS, and 2005.
8. Scroll down to a date and time and click on it to view the satellite image.

Example: View the satellite image taken on 2005-09-22 (date) at 08:10:07 GMT (time) or on 2005-09-23 (date) at 8:53:41 GMT (time). This image is of a storm over the Bering Sea that brought 65 mile-per-hour winds and 22-foot waves crashing over the seawall to flood Front Street and area shops in Nome on September 22 and 23, 2005.

Name: \_\_\_\_\_

## Levels V-VI Student Worksheet

### The View from Space

Youth Camp

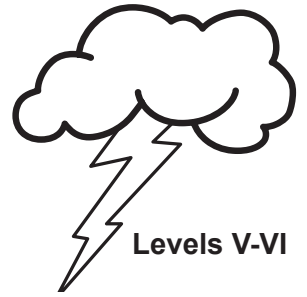

1. Satellites orbit Earth gathering information in the form of radio waves, then beam this information back down to Earth. Circle the types of information made available due to satellites.
    - a. weather maps
    - b. satellite images
    - c. both
  
  2. Notice that GINA's Swathviewer gives the Latitude and Longitude of any point. Click on the approximate location of your village and write down the Latitude and Longitude.
-